



MAXIMA[®]



ONLY FOR REAL PROFESSIONALS



GENEMAX 3500 IO

User Manual

SERIAL NUMBER M

INVERTER GENERATOR Owner's Manual

GENEMAX 3500 IO

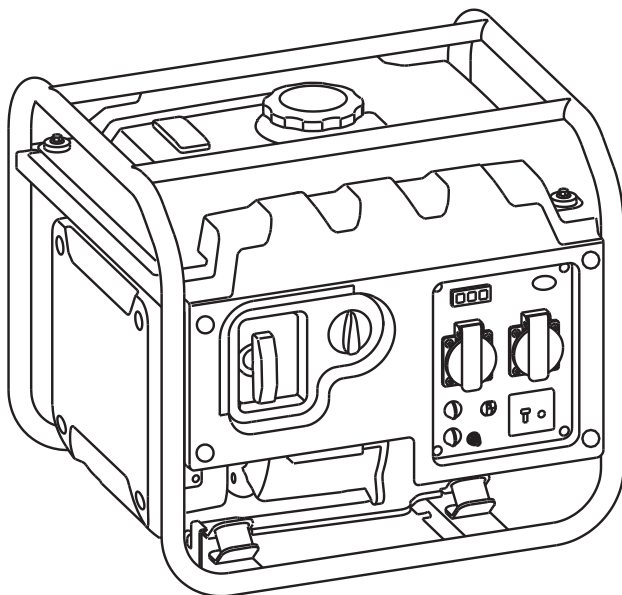

Tips—read this manual carefully before operating this generator.

Save this operating manual properly and carry it with the generator for the convenience of emergency query in the future. This manual constitutes one permanent element of the generator. This manual shall be provided along with the generator set when you lend or resell it.

Relevant information and technical specifications defined in this manual take effect when printing is approved, with the contents based on the equipment in production at time of publication. Manufacturer reserves the rights to modify and improve any parts described in the text without prior notice.

Contents

1	Foreward	07
2	Safety Information	08-11
3	Control Function	12-18
4	Pre-operation	19-20
5	Operation	21-27
6	Application Range	28-34
7	Storage	35
8	Troubleshooting	36
9	Parameters	37
10	Electrical Schematic Diagram	38-40

Foreward

Thank you for purchasing a generator. We recommend that the operator read this manual carefully before use this generator, and fully comprehend all requirements and operating procedure concerning the generator. In case of any questions about this manual, contact the recent authorized dealer for startup, operation, maintenance program and so on. The technician will teach you how to use the generator in a correct and safe manner. We also recommend that the operator consult startup and operating procedure of this generator when buying it.

Safety precautions

This generator will work in a safe, effective and reliable way only when it is kept, operated and maintained properly. Before operation or maintenance of the generator, the operator should:

- Know well and strictly observe local laws and regulations.
- Read and observe all safety warnings in this manual and on the device.
- Let your family get familiar with all safety warnings in this manual.

It is impossible for manufacturers to predict all hazardous circumstances that may occur, for this reason, warnings in this manual and caution signs on the generator set may not cover all hazardous circumstances. If we do not give extra cautions for operating procedures, methods or techniques, operate the generator in such ways that helps guarantee personal safety, make sure no damage to generator set arises there from.

To make sure safe operation, Please read carefully three vital safety warnings in this manual and on the generator, preceded by a safety alert symbol  including:

DANGER

You WILL be KILLED or SERIOUSLY HURT if you don't follow instructions.

WARNING

You CAN be KILLED or SERIOUSLY HURT if you don't follow instructions.

CAUTION

You CAN be HURT if you don't follow instructions.

NOTICE

Your generator or other property could be damaged if you don't follow instructions.

2

Safety Information

Inverter Generator Owner's Manual

Safety Information



⚠ DANGER

Do not use it indoors.



⚠ DANGER

Keep the machine clean and avoid spilt combustibles including gasoline on it.



⚠ WARNING

Do not use it in a wet condition.

2

Safety Information

Inverter Generator Owner's Manual



⚠ WARNING

Turn the generator "OFF" when add fuel.



⚠ WARNING

Don't add fuel near the flammable thing or cigarette.

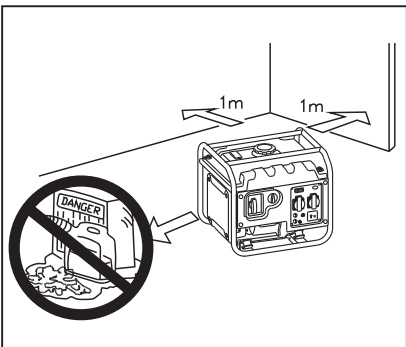

⚠ WARNING

Keep children and pets away from the area of operation. Do not place flammable objects close to the outlet valve when generator operation. Keep it at least 1m away from inflammables.

2

Safety Information

Inverter Generator Owner's Manual



⚠️ WARNING

Do not connect to a home power system.

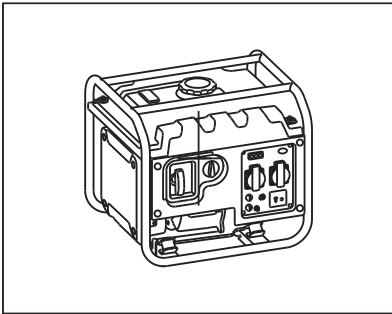

⚠️ WARNING

It must realize safe grounding.

NOTICE

Use the ground wire with enough electric flux.

Ground wire diameter : 0.12mm/A
EX:10A-1.2mm

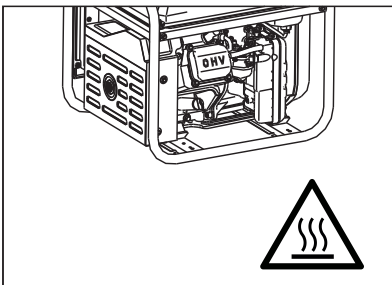

⚠️ WARNING

The generator surface has high temperature, avoid scalding.
Pay attention to the warnings on the generating set.

⚠️ WARNING

- A warning reminding the user that he shall conform to regulations of electrical safety applicable to the place where the generating sets are used.
- A warning on the requirements and the precautions to be respected by the user in the case of re-supply by generating sets of an installation, depending on existing protective measures in this installation and applicable regulations.

2

Safety Information

Inverter Generator Owner's Manual

Connection to a home power supply

If the generator is to be connected to a home power supply as a standby, connection shall be performed by a professional electrician or by another person with proficient electrical skill.

When the loads are connected to the generator, please carefully check whether electrical connections are safe and reliable. Any improper connection may cause damage to the generator, or cause a fire.

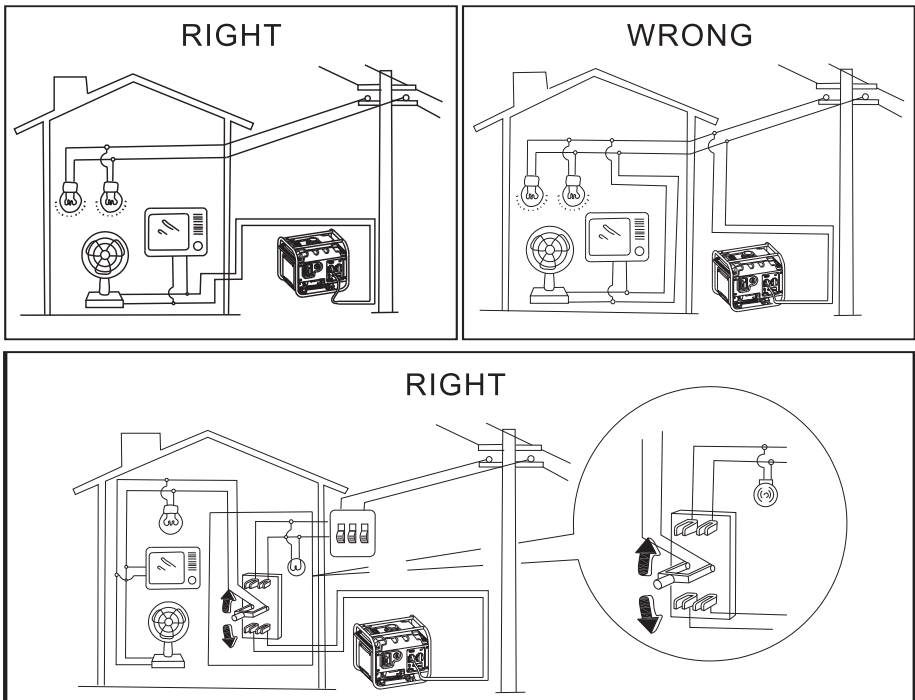

Others

Make sure Inverter ducted fan, muffler louver and the inverter bottom side cooling well and without chips, mud and water come in. it may damage the generator, inverter or alternator if the cooling vent blocked. Do not mix the generator with other stuff if moving, storing or running the unit, It may cause generator damage or bring property safety issue when the inverter in leakage.

3

Control Function Inverter Generator Owner's Manual

Control Function

DESCRIPTION

(1) Frame
 (2) Fuel gauge
 (3) Fuel tank cap
 (4) Fuel tank
 (5) Control panel
 (6) Ground terminal
 (7) 3 in 1 switch knob
 (8) Recoil starter grip
 (9) Inverter ducted fan
 (10) Muffler
 (11) Oil drain bolt
 (12) Oil filler cap
 (13) Air cleaner
 (14) Carburetor
 (15) Spark plug

Serial number
 T***YYMM*****
 The YYMM is year
 and month of
 manufactured.

CONTROL PANEL

100V 50/60Hz

(1) Oil warning light
 (2) Overload indicator light
 (3) AC pilot light
 (4) FS switch
 (5) DC receptacle
 (6) DC protector
 (7) AC receptacle
 (8) Ground terminal
 (9) AC receptacle
 (10) Parallel receptacle
 (11) Overload protector
 (12) ESC(engine smart control)

3

Control Function Inverter Generator Owner's Manual

120V 60Hz

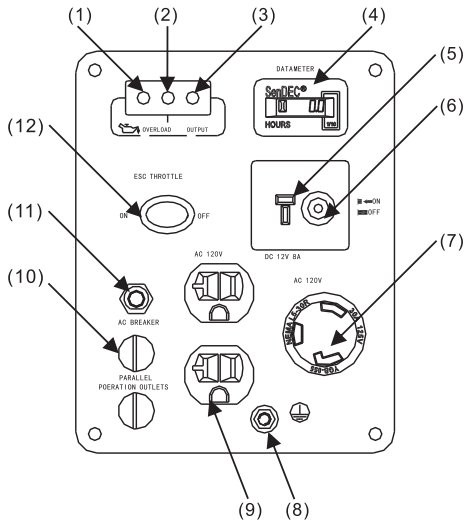

- (1) Oil warning light
- (2) Overload indicator light
- (3) AC pilot light
- (4) Hour meter
- (5) DC receptacle
- (6) DC protector
- (7) AC receptacle
- (8) Ground terminal
- (9) AC receptacle
- (10) Parallel receptacle
- (11) Overload protector
- (12) ESC(engine smart control)

230V 50Hz

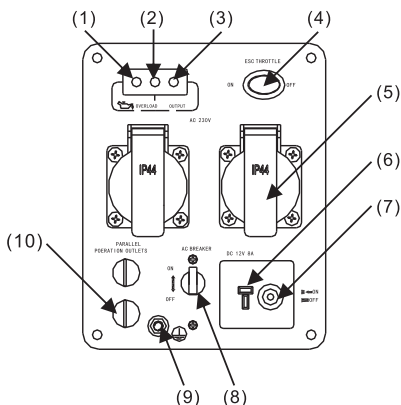

- (1) Oil warning light
- (2) Overload indicator light
- (3) AC pilot light
- (4) ESC(engine smart control)
- (5) AC receptacle
- (6) DC protector
- (7) DC receptacle
- (8) Overload protector
- (9) Ground terminal
- (10) Parallel receptacle

3

Control Function

Inverter Generator Owner's Manual

CONTROL FUNCTION

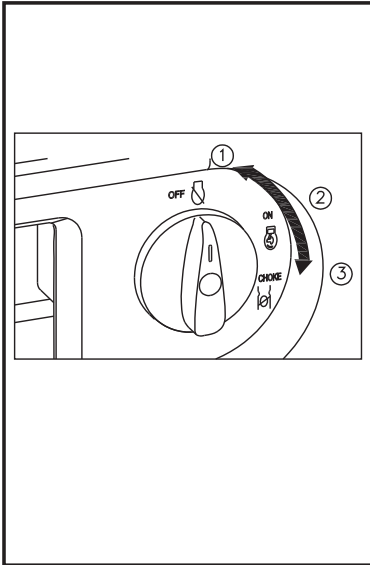

3 in 1 switch knob

- ① Engine/fuel valve "OFF"; Ignition circuit is switched off. Fuel is switched off. The engine will not run.
- ② Engine switch \fuel valve \chock. "ON" Ignition circuit is switched on. Fuel is switched on. Chock is switched on. The engine can be running.
- ③ Engine switch \fuel valve \chock. "ON" Ignition circuit is switched on. Fuel is switched on. Chock is switched on. The engine can be start.

TIP: The chock is not required to start a warm engine.

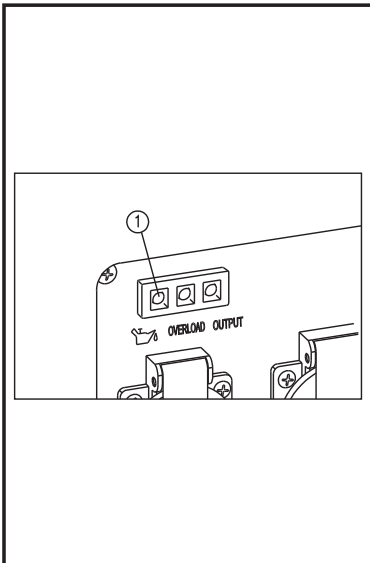

Oil warning light

When the oil level falls below the lower level, the oil warning light comes on and then the engine stops automatically. Unless you refill with oil, the engine will not start again.

Tip: If the engine stalls or does not start, turn the engine switch to "ON" and then pull the recoil starter. If the oil warning light flickers for a few seconds, the engine oil is insufficient. Add oil and restart.

3

Control Function

Inverter Generator Owner's Manual

Overload indicator light (Red)

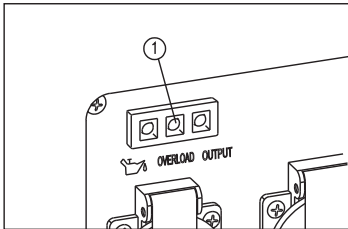

The overload indicator light comes on when an overload of a connected electrical device is detected, the inverter control unit overheats, or the AC output voltage rises. Then, the AC protector will trip, stopping power generation in order to protect the generator and any connected electric devices. The AC pilot light (Green) will go off and the overload indicator light (Red) will stay on, but the engine will not stop running.

When the overload indicator light comes on and power generation stops, proceed as follows:

1. Turn off any connected electric devices and stop the engine.
2. Reduce the total wattage of connected electric devices within the rated output.
3. Check for blockages in the cooling air Inlet and around the control unit. If any blockages are found remove.
4. After checking, restart the engine.

TIP : The overload indicator light may come on for a few seconds at first when using electric devices that require a large starting current, such as a compressor or a submersible pump. However, this is not a malfunction.

3

Control Function

Inverter Generator Owner's Manual

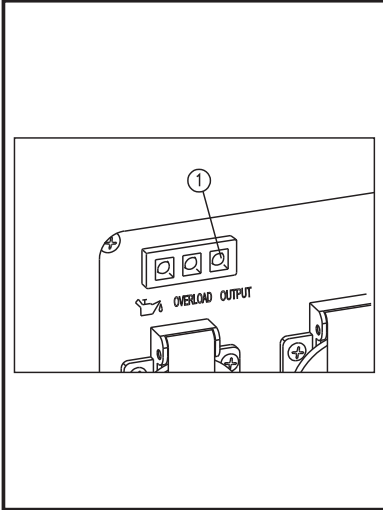

AC pilot light (Green)

The AC pilot light comes on when the engine starts and produces power.

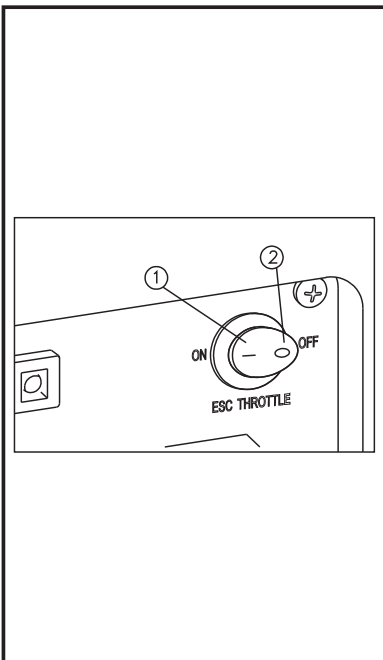

Engine smart control

- ① “ON”
When the ESC switch is turned to “ON”, the economy control unit controls the engine speed according to the connected load. The results are better fuel consumption and less noise.
- ② “OFF”
When the ESC switch is turned to “OFF”, the engine runs at the rated (3100r/min) Regardless of whether is a load connected or not.

Tip: The ESC must be turned to “OFF” when using electric devices that require a large starting current, such as a compressor or a submersible pump.

3

Control Function

Inverter Generator Owner's Manual

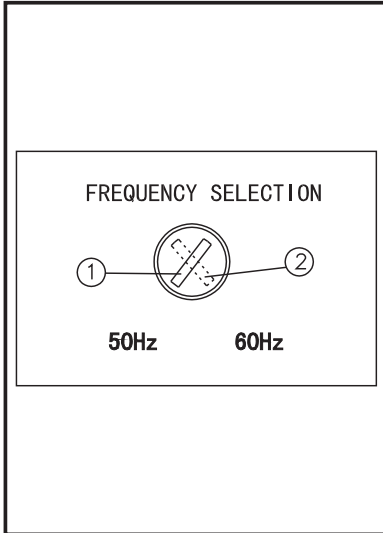

Frequency selection (FS) switch

- ① 50Hz
- ② 60Hz

If you need change the machine output frequency, please stop the generating set firstly, then adjust the position of frequency switch by screwdriver. Then restart it.

NOTICE

Frequency switch can change frequency only when the generator setting stops. The generator setting output frequency can't change if it operates.

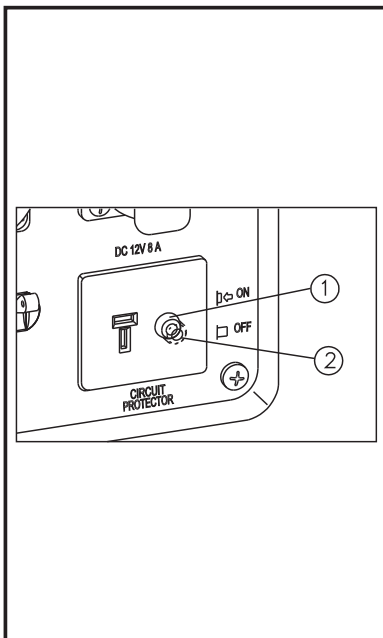

DC protector

The DC protector turns to “OFF” automatically when electric device being connected to the generator is operating and current above the rated flows. To use this equipment again, turn on DC protector by pressing its button to “ON” .

- ① “ON” Direct current is output.
- ② “OFF” Direct current is not output.

NOTICE

Reduce the load of the connected electric device below the specified rated output of the generator if the DC protector turns off. If the DC protector turns off again, stop using the device immediately and consult your generator dealer.

3

Control Function

Inverter Generator Owner's Manual

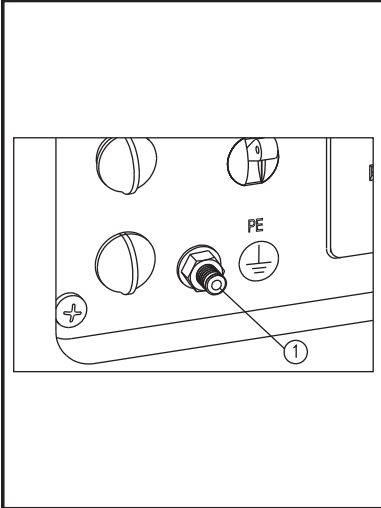

Ground (Earth) terminal

Ground (Earth) terminal ① connects the earth line for prevention of electric shock. When the electric device is earthed, always the generator must be earthed.

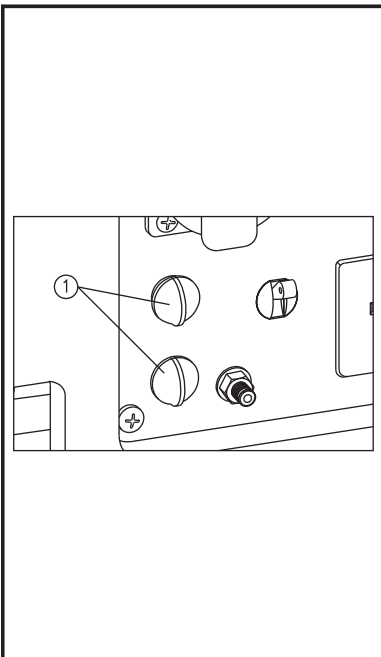

Parallel Operation Outlets

This is the terminal ① for connecting special cables for parallel running of two 3500io. The parallel running requires two 3500io and the special cables. (The rated output in parallel running is 5.6Kva and the rated current is 56A/100V;46.7A/120V;24.3A/230V.)

The handing, operation procedure and the notes on usage are described in the PARALLEL RUNNING KIT OWNER'S MANUAL included in the Parallel.

4

Pre-operation

Inverter Generator Owner's Manual

Pre-operation

NOTICE

Pre-operation checks should be made each time operation.

⚠ WARNING

The engine and muffler will be very hot after the engine has been run. Avoid touching the engine and muffler while they are still hot with any part of your body or clothing during inspection or repair.

Fuel

⚠ WARNING

- Fuel is highly flammable and poisonous. Check "SAFETY INFORMATION"(See page 2-5) carefully before filling.
- Do not overfill the fuel tank, otherwise it may overflow when the fuel warms up and expands. After fill the fuel, make sure the fuel tank cap is tightened securely.
- Immediately wipe off spilled fuel with a clean.
- Use only unleaded gasoline. The use of leaded gasoline will cause severe damage to internal engine parts.

Make sure enough gasoline in fuel tank.

Recommended fuel: Unleaded gasoline
 Fuel tank capacity: Total: 9.0L

- ① Fuel level gauge
 F (FULL)
 E (EMPTY)

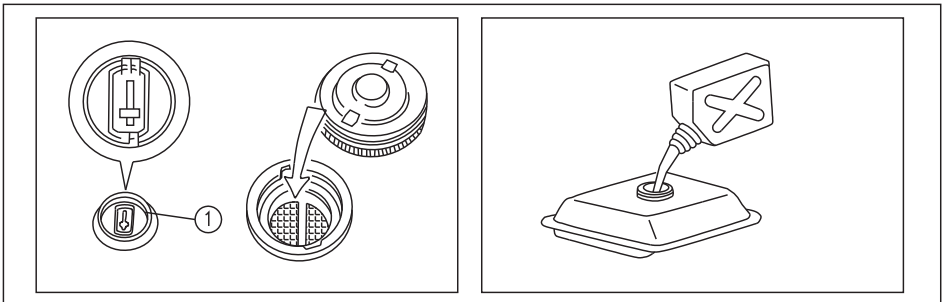

4

Pre-operation

Inverter Generator Owner's Manual

Engine Oil

The generator has been shipped without engine oil. Do not start the engine till fill with the sufficient engine oil.

Do not tilt the generator when adding engine. This could result in overfilling and damage to the engine.

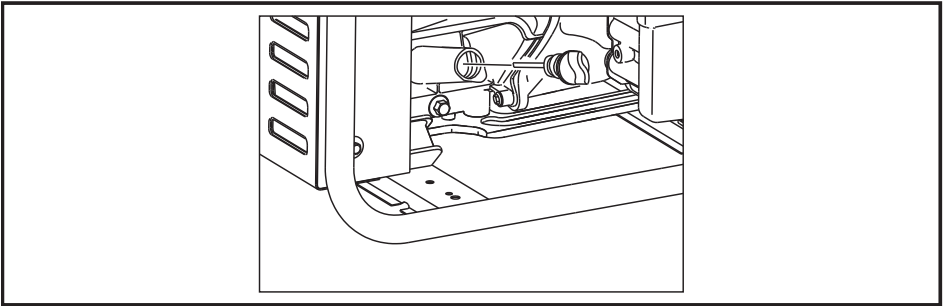

Oil level

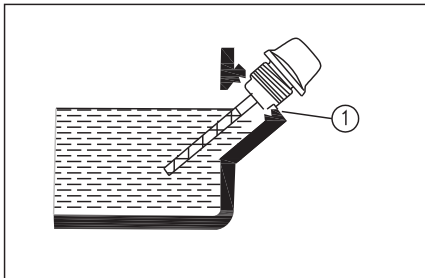

Recommended engine oil:

SAE 10W -30

Recommended engine oil grade:

API Service SE type or higher

Engine oil quantity:

0.6 L

Operation

NOTICE

Never operate the engine in a closed area or it may cause unconsciousness and death within a short time. Operate the engine in a well ventilated area. The generator has been shipped without engine oil. Do not start the engine till fill with the sufficient engine oil.

TIP:

- The generator can be used with the rated output load at standard atmospheric conditions.
- “Standard atmospheric conditions ”; Ambient temperature 25c.
- Barometric pressure 100kPa; Relative humidity 30%
- The output of the generator varies due to change temperature, altitude (lower air pressure at higher altitude) and humidity.
- The output of the generator is reduced when the temperature, the humidity and the altitude are higher than standard atmospheric conditions.
- Additionally, the load must be reduced when using in confined areas, as generator cooling is affected.

STARTING THE ENGINE

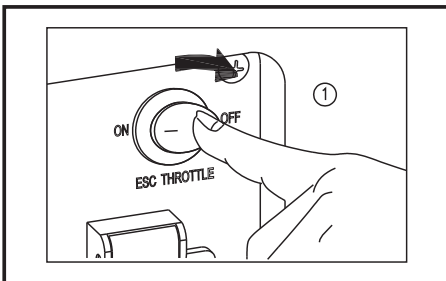

Before starting the engine, do not connect any electric devices.

Turn the ESC switch to “OFF” ①

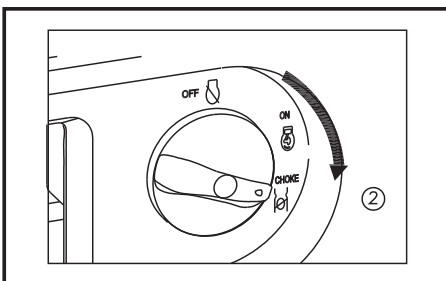

Turn the 3 in 1 switch to “CHOCK” ②

- a. Ignition circuit is switched on.
- b. Fuel is switched on.
- c. Chock is switched off.

TIP: The choke is not required to start a warm engine. Push the choke knob in to the position “ON”.



Operation

Inverter Generator Owner's Manual

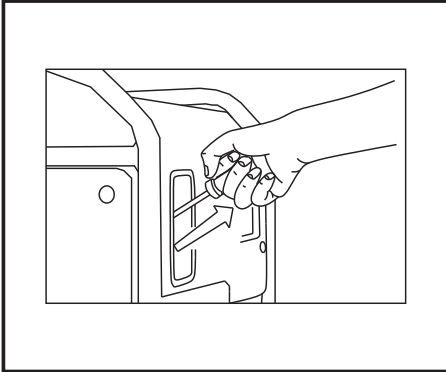

Grasp the carrying handle firmly to prevent the generator from falling over when pulling the recoil starter.

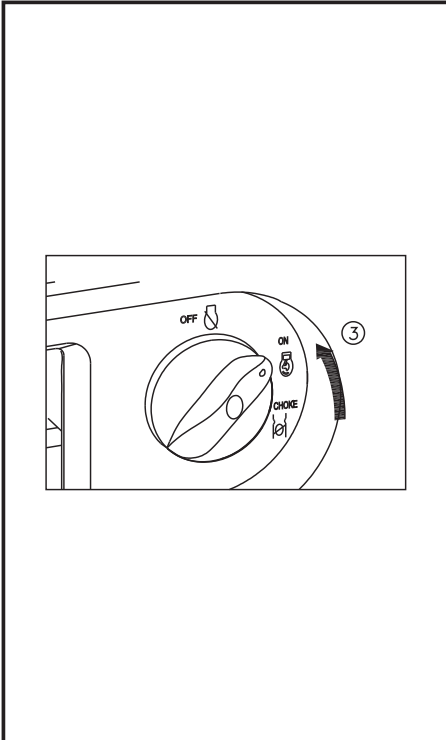

After the engine starts, warm up the engine until the engine does not stop when the choke knob is returned to the “ON” position ③.

TIP:

When starting the engine, with the ESC “ON” and there is no load on the generator:
 In ambient temperature below 0°C (32°F), the engine will run at the rated (3600r/min) for 5 minutes to warm up the engine.
 In ambient temperature below 5°C (41°F), the engine will run at the rated r/min (3600r/min) for 3 minutes to warm up the engine.
 The ESC unit operates normally after the above time period, while the ESC is “ON”.

STOP THE ENGINE

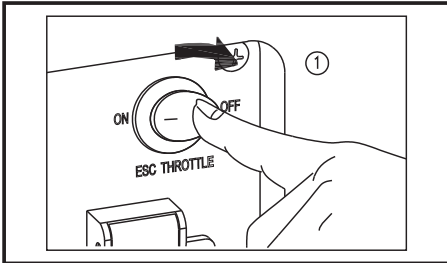

TIP: Turn off any electric devices.

1. Turn the ESC to "OFF" ① .
2. Disconnect any electric devices.

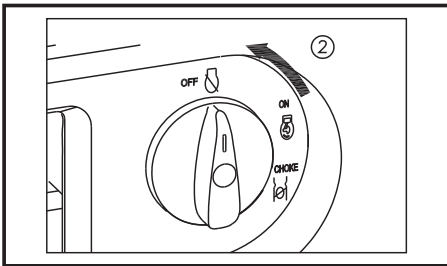

Turn the 3 in 1 switch to "OFF" ② .

- a. Ignition circuit is switched off.
- b. Fuel valve is switched off.

ALTERNATING CURRENT (AC) CONNECTION

⚠ WARNING

Be sure any electric devices are turned off before plugging them in.

NOTICE

- Be sure all electric devices including the lines and plug connections are in good condition before connection to the generator.
- Be sure the total load is within generator rated output.
- Be sure the receptacle load current is within receptacle rated current.

TIP: Make sure to ground (Earth) the generator. When the electric device is earthed, always the generator must be earthed.

1. Start the engine.
2. Turn the ESC to "ON".
3. Plug in to AC receptacle.
4. Make sure the AC pilot light is on.
5. Turn on any electric devices.



TIP: The ESC must be turned to “OFF” before increasing engine speed to rated rpm.

- Most motorized appliances require more than their electrical rating for startup. When an electrical motor is started, the overload indicator (red) may come on. This is normal if the overload indicator (red) goes off within 4 seconds. If the overload indicator (red) stays on, consult your generator dealer.
- If the generator is connected to multiple loads or electricity consumers, please remember to first connect the one with the highest starting current. And last connect the one with the lowest starting current.
- If the generator is overload, or if there is a short circuit in a connected appliance, the overload indicator (red) will go ON. The overload indicator (red) will stay ON, and after about 4 seconds, current to the connected appliance(s) will shut off, and the output indicator (green) will go OFF. Stop both engines and investigate the problem. Determine if the cause is a short circuit in a connected appliance or an overload, correct the problem and restart the generator.

BATTERY CHARGING

TIP:

- The generator DC rated voltage is 12V.
- Start the engine first, and then connect the generator to the battery for charging.
- Before starting to charge the battery, make sure that the DC protector is turned on.

- 1.Start the engine.
- 2.Connect the red battery charger lead to the positive (+) battery terminal.
- 3.Connect the black battery charger lead to the negative (-) battery terminal.
- 4.Turn the ESC “OFF” to start battery charging.



NOTICE

- Be sure the ESC is turned off while charging the battery.
- Be sure to connect the red battery charger lead to the positive (+) battery terminal, and connect the black lead to the negative (-) battery terminal. Do not reverse these positions.
- Connect the battery charger leads to the battery terminals securely so that they are not disconnected due to engine vibration or other disturbances.
- Charge the battery in the correct procedure by following instructions in the owner's manual for the battery.
- The DC protector turns off automatically if current above the rated flows during battery haring. To restart charging the battery, turn he DC protector on by pressing its button to "ON". If the DC protector turns off again, top charging the battery immediately and consult your generator dealer.

TIP:

- Follow instructions in the owner are manual for the battery to determine the end of battery charging.
- Measure the specific gravity of electrolyte to determine if the battery is fully charged. At full charge, the electrolyte specific gravity is between 1.26 and 1.28.
- It is advisable to check the specific gravity of the electrolyte at least once every hour to prevent overcharging the battery.

WARNING

- Never smoke or make and break connections at the battery while charging. Sparks may ignite the battery gas.
- Battery electrolyte is poisonous and dangerous, causing severe burns, etc. contains sulfuric (sulphuric) acid. Avoid contact with skin, eyes or clothing.

Antidote:

External- Flush with water.

INTERNAL- Drink large quantities of water or milk. Follow with milk of magnesia, beaten egg or vegetable oil.

Call physician immediately.



EYES: Flush with water for 15 minutes and get prompt medical attention. Batteries produce explosive gases. Keep sparks, flame, cigarettes, etc., away. Ventilate when charging or using in closed space. Always cover eyes when working near batteries.

KEEP OUT OF REACH OF CHILDREN

AC parallel operation

Before connection an appliance to either generator, make sure that it is in good working order and that its electrical rating does not exceed that of the receptacle.

During parallel operation, the ESC switch should be in the same position on both generators.

1. Connect the parallel operation cable between the 3500io to either an 3500io or companion generator following the instructions supplied with the cable kit.
2. Start the engines and make sure the output indicator (green) on each generator comes on.
3. Plug an appliance into the AC receptacle.
4. Turn on the appliance.

AC Parallel Operation Applications

TIP:

- Make sure that it is in good working order. A faulty appliance or power cord can create a potential for electrical shock.
- If an appliance begins to operate abnormally, becomes sluggish, or stops suddenly, turn it off immediately. Disconnect the appliance and determine whether the problem is the appliance, and determine whether the problem is the appliance or the rated load capacity of the generator has been exceeded.
- Make sure that the combined electrical rating of the tools or appliance do not exceed that of the generator. Never exceed the maximum may be used for no more than 30 minutes.
- Never connect different generator models.
- Don't remove the parallel operation cable when the generator operation.
- For single generator operation, the parallel operation cable must be removed.





**⚠ WARNING**

- Substantial overloading that continuously lights the overload indicator (red) may damage the generator
- Marginal overloading that temporarily light the overload indicator (red) may shorten the service life of the generator.
- Limit operation requiring maximum power to 30 minutes.
- Maximum power in parallel operation is; 6.0kVA.
- For continuous operation, do not exceed the rated power.
- Rated power in parallel operation is: 5.6kVA.

6

Application Range Inverter Generator Owner's Manual

When using the generator, make sure the total load is within rated output of a generator. Otherwise, generator damage may occur.

AC				DC 
Power factor	1	0.8-0.95	0.4-0.75 (Efficiency 0.85)	
3500io	~3000W	~2400W	~1200W	Rated voltage 12v Rated current 8A

TIP:

- “~” means below.
- Application wattage indicates when each device is used by itself.
- The simultaneous usage of AC and DC power is possible but total wattage should not exceed the rated output.

EX:

Generator rated output		3000VA
Frequency	Power factor	
AC	1.0	~3000W
	0.8	~2400W
DC	--	96W(12V/8A)

The overload indicator light comes on when total wattage exceeds the application range. (See page 12 for more details.)

NOTICE

- Do not overload. The total load of all electrical appliances must not exceed the supply range of the generator. Overloading will damage the generator.
- When supplying precision equipment, electronic controllers, PCs, electronic computers, microcomputer based equipment or battery chargers, keep the generator a sufficient distance away to prevent electrical interference from the engine. Also ensure that electrical noise from the engine does not interfere with any other electrical devices located near the generator.

6

Application Range

Inverter Generator Owner's Manual

NOTICE

- If the generator is to supply medical equipment, advice should first be obtained from the manufacturer, a medical professional or hospital.
- Some electrical appliances or general-purpose electric motors have high starting currents, and cannot therefore be used, even if they lie within the supply ranges given in the above table. Consult the equipment manufacturer for further advice.

Periodic maintenance

Safety is an obligation of the owner. Periodic inspection, adjustment and lubrication will keep your generator in the safest and most efficient condition possible. The most important points of generator inspection and lubrication are explained on the following pages.

⚠ WARNING

If you are not familiar with maintenance work, have a generator dealer do it for safety.

Maintenance chart

⚠ WARNING

Stop the engine before starting maintenance work.

Use only your generator dealer specified genuine parts for replacement. Ask an authorized your generator dealer for further attention.

Item	Routine	Pre-operation check(daily)	6 months or 100 Hr	12 months or 300 Hr
Spark plug	Check condition. Clean and replace if necessary.	○		
Fuel	Check fuel level and leakage.	○		
Fuel hose	Check fuel hose for cracks or damage, Replace if necessary.	○		
Oil	Check oil level in engine.	○		
	Replace		○ (1)	

6

Application Range

Inverter Generator Owner's Manual

Item	Routine	Pre-operation check(daily)	6 months or 100 Hr	12 months or 300 Hr
Air filter	Check condition. Clean.		○ (2)	
Muffler screen	Check condition. Clean and replace if necessary.		○	
Spark arrester	Check condition. Clean and replace if necessary.		○	
Fuel filter	Clean and replace if necessary.			○
Crankcase breather hose	Check hose weather for cracks or damage. Replace if necessary.			○
Cylinder head	Decarbonizes cylinder head More frequently if necessary			★
Valve clearance	Check and adjust when engine is cold			★
Fittings/ fasteners	Check all fittings and fasteners. Correct if necessary.			★
The point where abnormality was recognized by use		○		

- (1) Initial replacement of the engine oil is after before one month or after 20 hours of operation.
 - (2) The air filter needs to be cleaned more frequently when using in unusually wet or dusty areas.
- ★ Since these items require tools, date and technical skills have a dealer perform the service.

6

Application Range

Inverter Generator Owner's Manual

SPARK PLUG INSPECTION

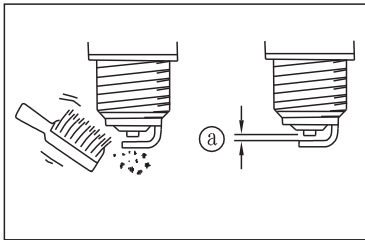
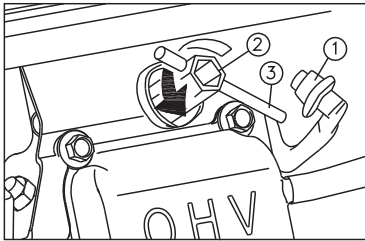

The spark plug is important engine components, which should be checked periodically.

1. Noise suppressor cap assy ① , install spark plug wrench box ② on the spark plug appropriately.
2. Insert the handlebar③ into the tool and turn it counterclockwise to remove the spark plug.
3. Check for discoloration and remove the carbon. The porcelain insulator around the center electrode of spark plug should be a medium-to- light tan color.
4. Check the spark plug type and gap.

Standard spark plug:
 BPR6ES/BP6ES (NGK)
 F7RTC/F7TC
 Spark plug gap: 0.6-0.7mm

5. Install the spark plug.

TIP:

If a torque wrench is not available when installing a spark plug, a good estimate of the correct torque is 1/4-1/2 turn past finger tight. However, the spark plug should be tightened to the specified torque as soon as possible.

6. Install the spark plug cap and spark plug cover.

6

Application Range

Inverter Generator Owner's Manual

CARBURETOR ADJUSTMENT

The carburetor is a vital part of the engine. Adjusting should be left to a dealer with the professional knowledge, specialized date, and equipment to do so properly.

CLEAN FUEL FILTER

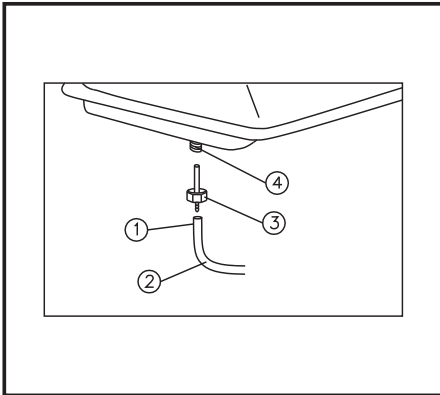

1. Drain the fuel in the fuel tank. Hold the tube clip ① toward downward and pull out the fuel tube ② which connect on the fuel tank, then disassemble fuel filter.
2. Put the fuel filter ③ into non-combustible or higher flash point solvent and clean it.
3. Assemble fuel filter to the main jet ④ on the fuel tank, then assemble fuel tube to main jet on the fuel tank and install tube clip.

ENGINE OIL REPLACEMENT

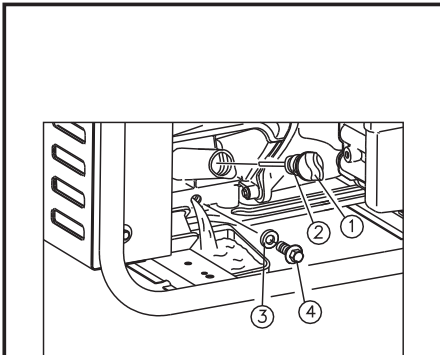

- ① Oil cap
- ② O-ring
- ③ Oil filler cap packing
- ④ Oil drain bolt

Avoid draining the engine oil immediately after stopping the engine. The oil is hot and should be handled with care to avoid burns.

1. Place the generator on a level surface and warm up the engine for several minutes.
2. Remove the oil filler cap.
3. Place an oil pan under the engine, remove the oil drain bolt, drain the oil from the oil tank.
4. Check oil filler cap, O-ring, Oil drain bolt, Oil filler cap packing. Replace immediately new one if it damages.
5. Assemble oil drain bolt and oil filler cap packing.
6. Add oil till to a suitable level, tighten oil filler cap.

6

Application Range

Inverter Generator Owner's Manual

NOTICE

Do not tilt the generator when adding engine oil. This could result in overfilling and damage to the engine. Don't make foreign body fall into engine.

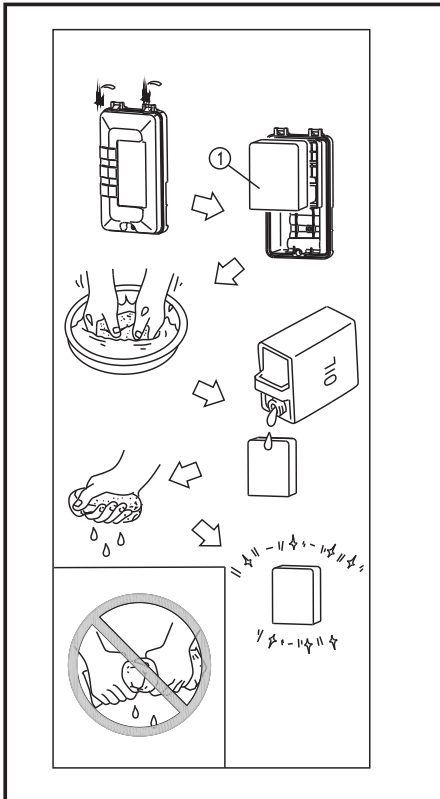
AIR FILTER

1. Remove the air filter cover and foam element①.
2. Wash the foam element in solvent and dry it..
3. Add oil for the foam element and squeeze out excess oil. The foam element should be wet but not dripping, avoid be damage.
4. Insert the foam element into the air filter case.

TIP:

- Be sure the foam element sealing surface matcher the air filter so there is no air leak.
 - The engine should never run without the air filter; excessive poisonous gas will lead to piston and cylinder wear.
5. Install the air filter case cover in its original position.

6

Application Range

Inverter Generator Owner's Manual

MUFFLER SCREEN

⚠ WARNING

The engine and muffler will be very hot after the engine has been run. Avoid touching the engine and muffler while they are still hot with any part of your body or clothing during inspection or repair.

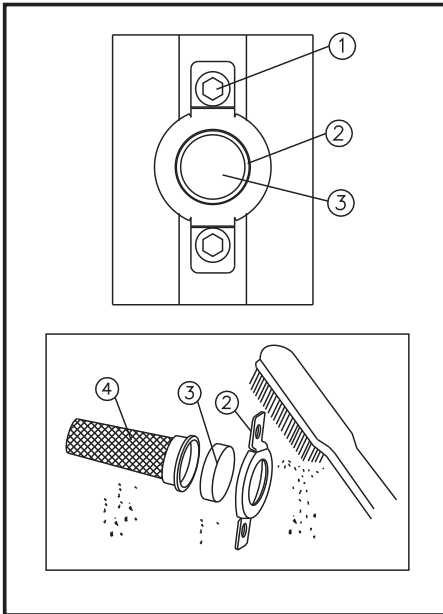

1. Remove the bolt ① , Remove the muffler cap ② , Remove the muffler screen ③ , Remove the spark arrester ④ .
2. Clean the carbon on the muffler screen by wire brush.
3. Check the muffler screen and spark arrester, replace if it damage.
4. Install spark arrester.

⚠ WARNING

Never use an engine without an appropriate spark arrester in the forest areas! Doing so may cause a fire!

Storage

Long term storage of your machine will require some preventive procedures to guard against deterioration.

DRAIN THE FUEL

1. Turn the 3 in 1 switch to "OFF".
2. Remove the fuel tank cap, remove the filter. Extract the fuel from the fuel tank into an approved gasoline container using a commercially available hand siphon. Then, install the fuel tank cap.
3. Fuel is highly flammable and poisonous. Check "SAFETY INFORMATION" (See page 1) carefully immediately wipe off spilled fuel with a clean, dry, soft cloth, since fuel may deteriorate painted surfaces or plastic parts.
4. Start the engine and leave it run until it stops. The engine stops in approx. 20 mins. Time by running out of fuel.

TIP:

- Do not connect with any electrical devices. (Unloaded operation).
 - Duration of the running engine depends on the amount of the fuel left in the tank.
5. Drain the fuel from the carburetor by loosening the drain screw on the carburetor float chamber.
 6. Turn the 3 in 1 switch to "OFF".
 7. Tighten the drain screw.

ENGINE

Perform the following steps to protect the cylinder, piston ring, etc. from corrosion.

1. Remove the spark plug; pour about one table-spoon of SAE 10W-30 into the spark plug hole and reinstall the spark plug.
2. Recoil start the engine by turning over several times (with 3 in 1 switch knob off) to coat the cylinder walls with oil.
3. Pull the recoil starter until you feel compression. (This prevents the cylinder and valves from rusting).
4. Then stop pulling.
5. Clean the outside of engine and spray antirust additive.
6. Store the generator in a dry, well-ventilated place, with the cover placed over it.
7. Lay the engine vertically.

8

Troubleshooting

Inverter Generator Owner's Manual

Troubleshooting

ENGINE CAN'T START

1. Fuel systems

- No gasoline in the fire chamber.
- No fuel in the fuel tank...add fuel.
- Fuel in tank.
- Clogged fuel filter Clean fuel filter.
- Clogged carburetor.... Clean carburetor.

2. Engine oil system

- Oil level is low.... Add engine oil.

3. Electrical systems

- Put the 1 in 3 switch to “CHOKE” and pull the recoil starter...Poor spark.
- Spark plug dirty with carbon or wet.... Remove carbon or wipe spark plug dry.
- Faulty ignition system.... Consult your generator dealer.

GENERATOR WON'T PRODUCE POWER

- Safety device (DC protector) to “OFF”.... Press the DC protector to “ON”.
- The AC pilot light (Green) go off Stop the engine, and then restart.

9

Parameters

Inverter Generator Owner's Manual

Parameters

	Model No.	3500io
Generator	Type	Inverter
	Rated frequency /Hz	50/60/50&60
	Rated voltage /V	100/120/230
	Max. output power /KVA	3.3
	Rated output power /KVA	3.0
	Power factor	1.0
	AC output quality	ISO8528 G2
	THD/%	≤5
	Noise Level dB/LPA (3/4 load) (3/4 load)dB	68.5
	DC Output/ V-A	12-8
	Overload Protect	DC
AC		Control by inverter overload protect program
Engine	Engine	170F-3
	Engine type	Single cylinder, 4-Stroke, forced air cooling, OHV
	Displacement/cc	212
	Fuel type	Unleaded Gasoline
	Fuel Tank capacity/L	9
	Continue Running Time (at rated power)	6
	Engine Oil Capacity/L	0.6
	Spark Model No.	BPR6ES/BP6ES(NGK) F7RTC/F7TC
	Starting mode	Recoil starter
Generator	Length×Width×Height/mm	484×420×417
	Net weight/kg	34

10

Electrical Schematic Diagram Inverter Generator Owner's Manual

Electrical Schematic Diagram

● A 100V 50/60Hz

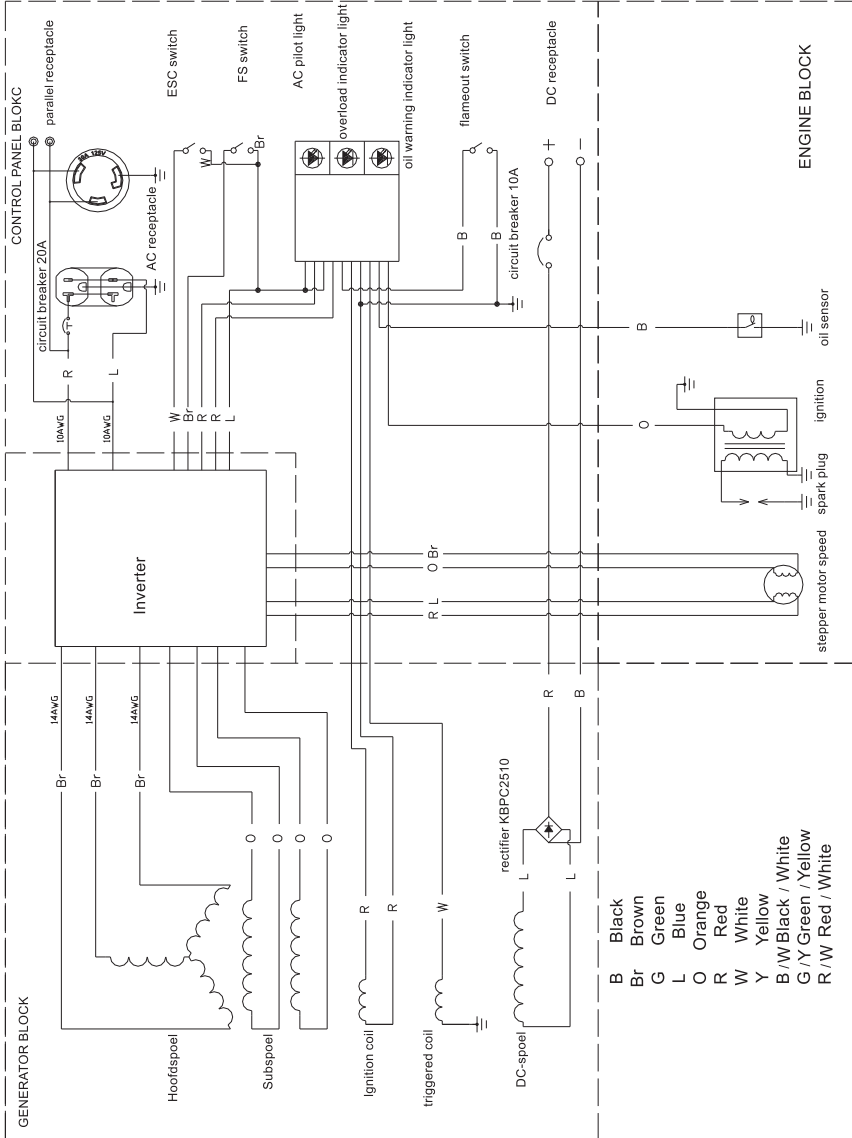

10

Electrical Schematic Diagram Inverter Generator Owner's Manual

B 120V 60Hz

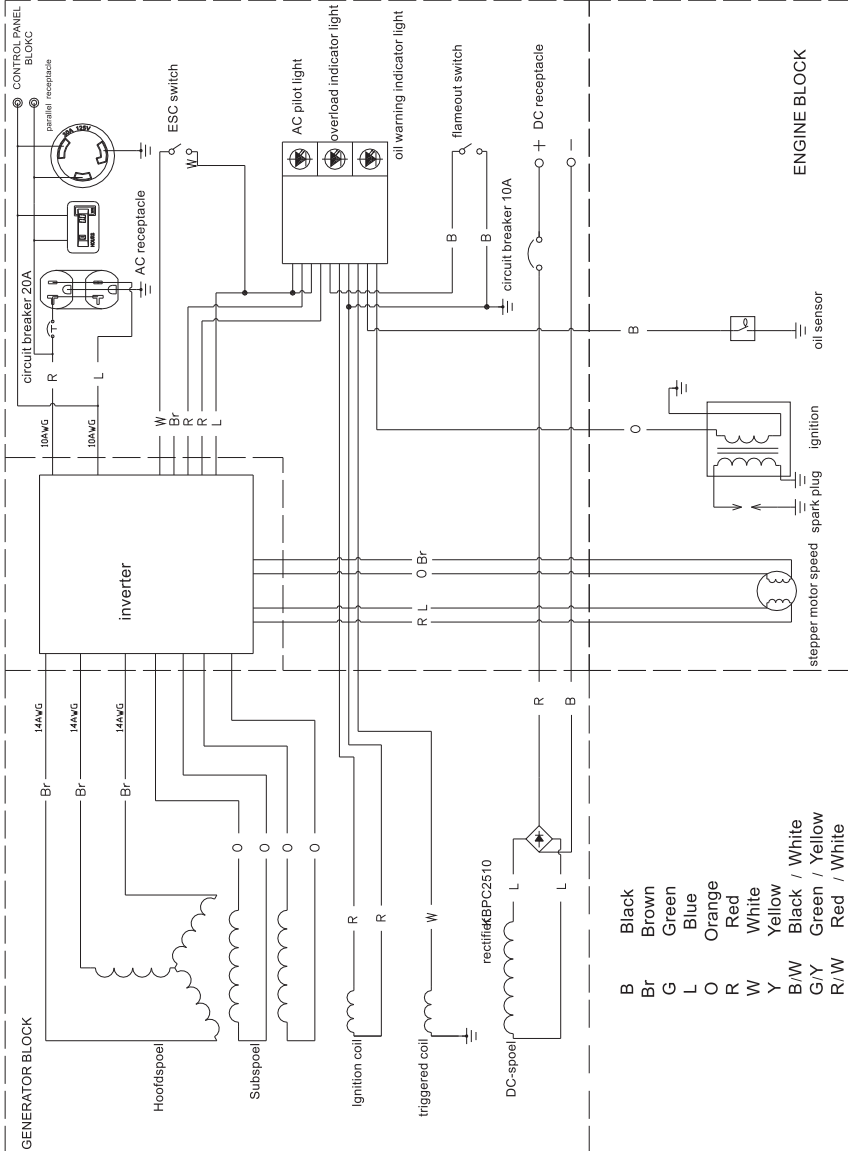

10

Electrical Schematic Diagram Inverter Generator Owner's Manual

● C 230V 50Hz

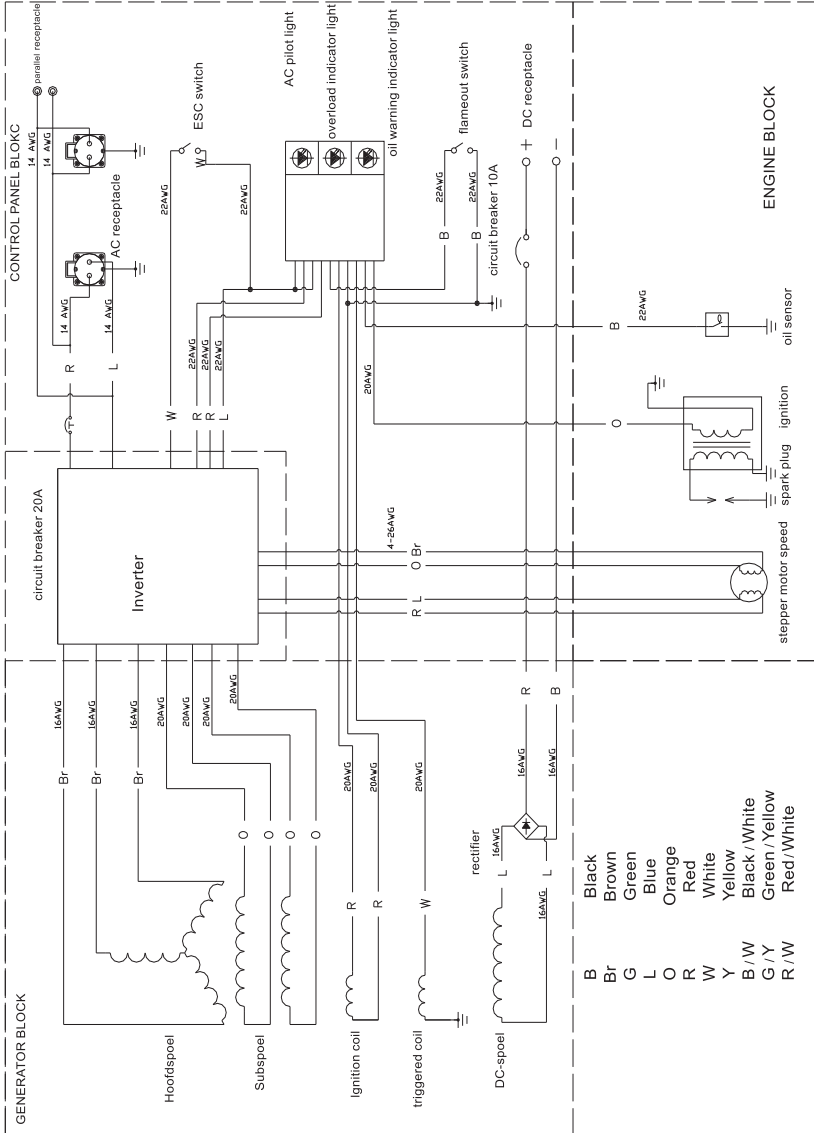

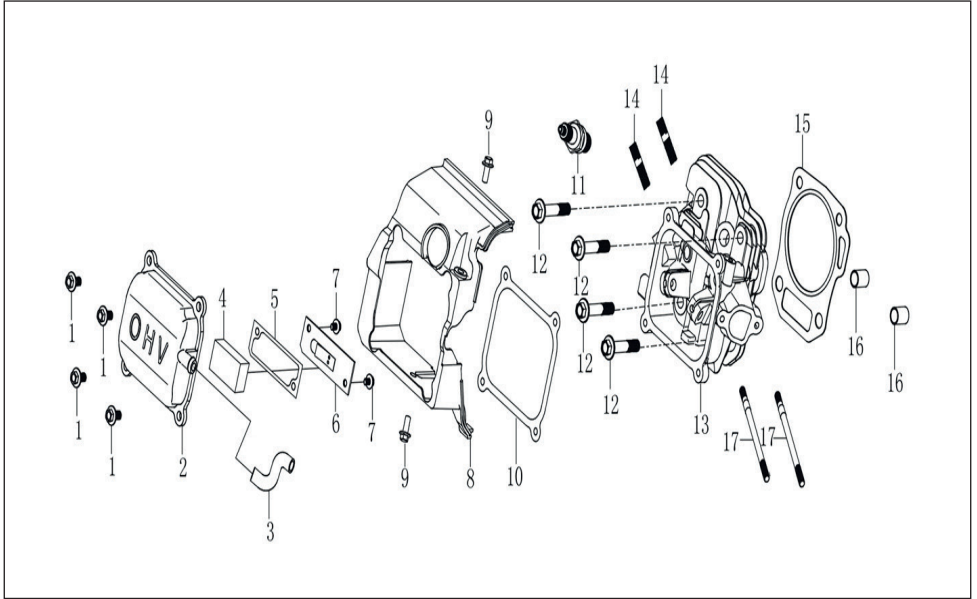

CYLINDER HEAD

Ser.No	P/N Maxima	Description	Quantity
1	GEN380140215	BOLT, FLANGE M6X14	4
2	GEN120230109	COVER, HEAD	1
3	GEN380741155	TUBE, BREATHER	1
4	GEN150290027	FILTER, HEAD COVER	1
5	GEN110850018	GASKET, CAP, BREATHER	1
6	GEN110840024	CAP, BREATHER CHAMBER	1
7	GEN380140429	BOLT, FLANGE M5X10	2
8	GEN160190078	SHROUD COMP	1
9	GEN380140011	BOLT, FLANGE, 6X10	2
10	GEN120250043	PACKING, HEAD COVER	1
11	GEN270960025	PLUG, SPARK F7TC	1
12	GEN380140336	BOLT, FLANGE, M8X60	4
13	GEN120080532	HEAD COMP, CYLINDER	1
14	GEN380180098	BOLT, STUD, EX. M8X34	2
15	GEN120150193	GASKET, CYLINDER	1
16	GEN380600117	PIN, DOWEL	2
17	GEN380180095	BOLT, STUD, IN M6X96	2

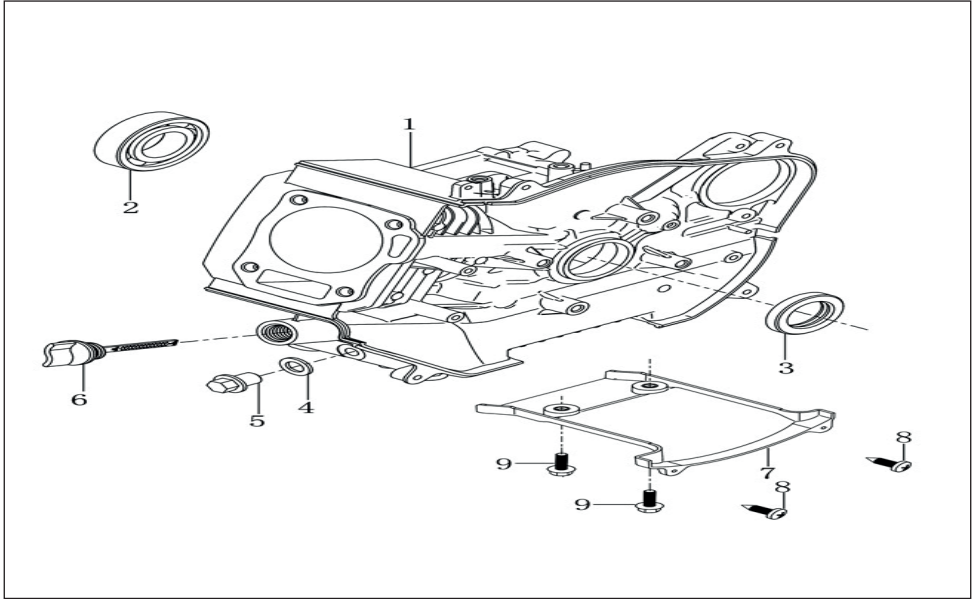

CRANKCASE			
Ser.No	P/N Maxima	Description	Quantity
1	GEN110810313	CRANK CASE	1
2	GEN380630417	BEARING 6205	1
3	GEN380650347	OIL SEAL 25×41.25×6	1
4	GEN380450514	WASHER, DRAIN PLUG 10×16×1.5	1
5	GEN110260025	BOLT, DRAIN PLUG M10×1.25×15	1
6	GEN110690073	CAP ASSY.	1
7	GEN160200054	BOTTOM, GUARD SHIELD	1
8	GEN380310117	SELT THREADING SCREW	2
9	GEN380140215	BOLT, FLANGE M6X14	2

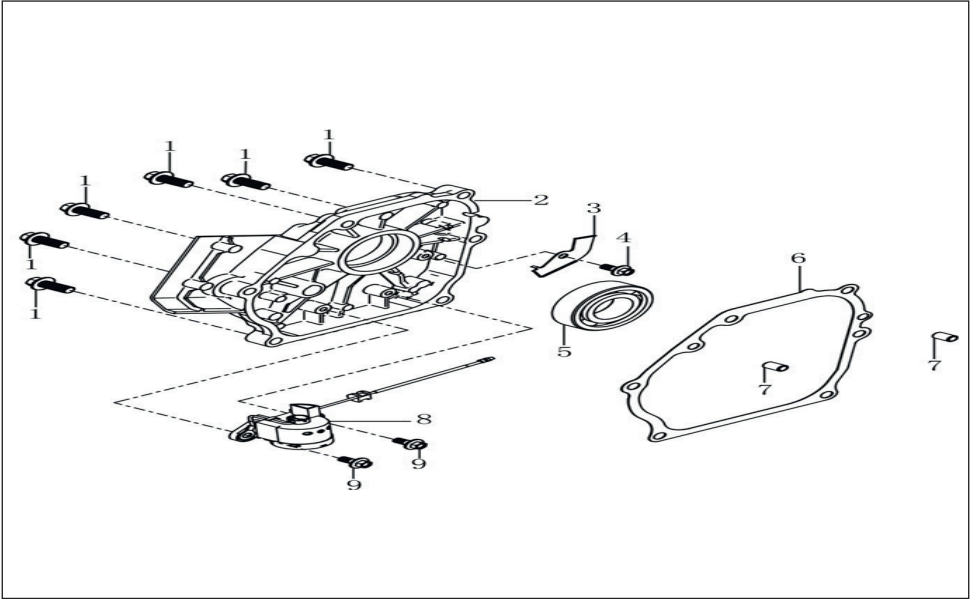

CRANKCASE COVER

Ser.No	P/N Maxima	Description	Quantity
1	GEN380140028	BOLT, FLANGE M8×32	6
2	GEN110820122	COVER, CRANKCASE	1
3	GEN110480032	PLATE	1
4	GEN380140011	BOLT, FLANGE M6×10	1
5	GEN380630417	BEARING 6205	1
6	GEN110830031	PACKING ,CASE COVER	1
7	GEN380600120	PIN, DOWEL 8×14	2
8	GEN281850237	OIL LEVEL SWITCH	1
9	GEN380140215	BOLT, FLANGE M6×14	2

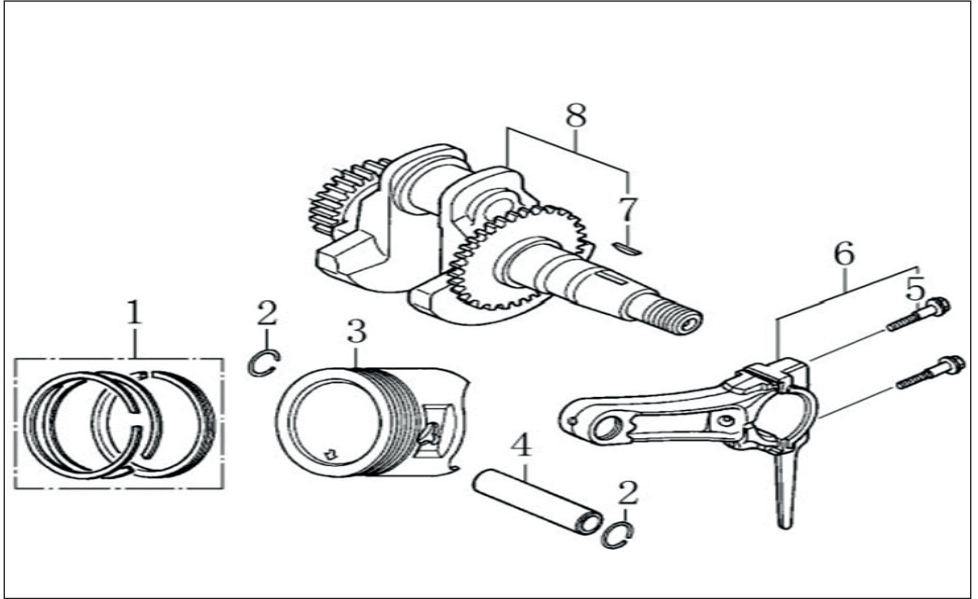

CRANKSHAFT/PISTON			
Ser.No	P/N Maxima	Description	Quantity
1	GEN130070187	RING SET	1
2	GEN380560056	CLIP, PISTON PIN	2
3	GEN130030208	PISTON	1
4	GEN130060031	PIN, PISTON	1
5	GEN130180001	BOLT,CONNECTING ROD	2
6	GEN130150054	ROD ASSY ., CONNECTING	1
7	GEN380620050	KEY	1
8	GEN130290447	CRANKSHAFT COMP	1

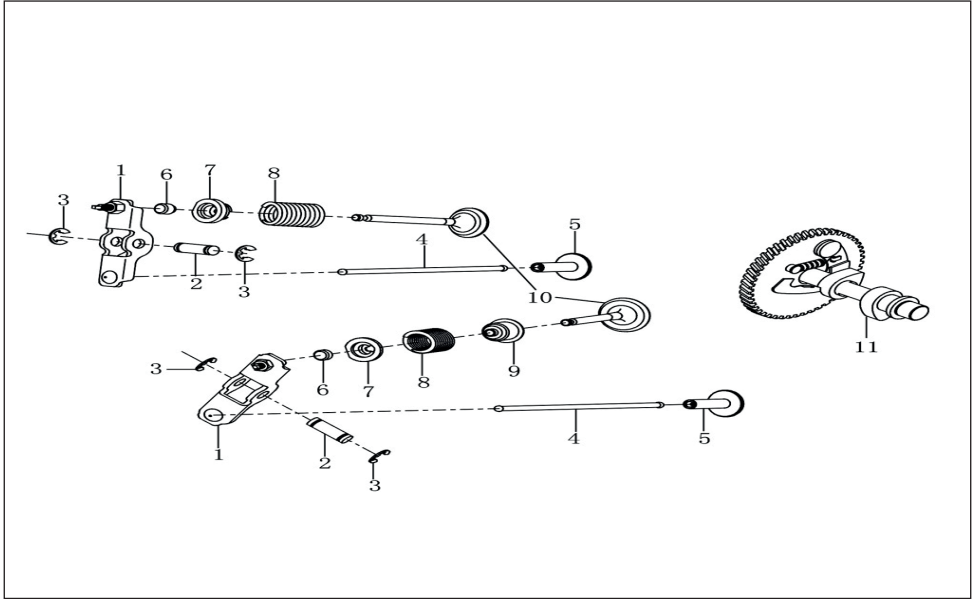

ROCKER,CAMSHAFT

Ser.No	P/N Maxima	Description	Quantity
1	GEN140450056	ARM COMP.	2
2	GEN141730001	VALVE ROCKER SHAFT	2
3	GEN380570024	LOCKER	2
4	GEN140670041	ROD, PUSH	2
5	GEN140690003	LIFTER VALVE	2
6	GEN140320001	ROTATOR, VALVE	2
7	GEN140380017	RETAINER, VALVE SPRING	2
8	GEN140340022	SPRING, VALVE	2
9	GEN140400016	SEAL, GUIDE	1
10	GEN500550041	VALVE COMP.	1
11	GEN140020114	CAMSHAFT ASSY.	1

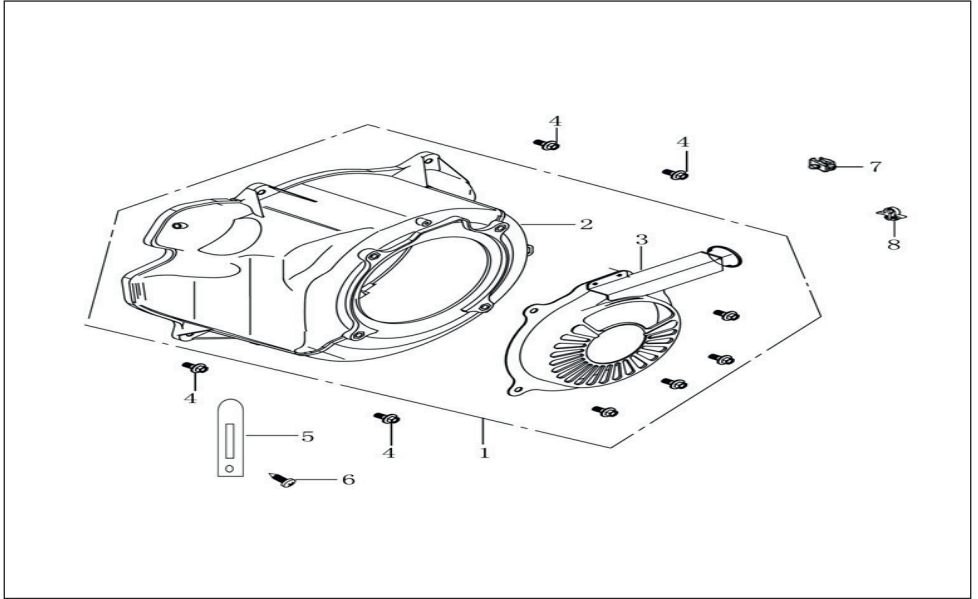

STARTER SUBASSEMBLY			
Ser.No	P/N Maxima	Description	Quantity
1	GEN160210096	COVER COMP., FAN	1
2	GEN160210097	COVER COMP., FAN	1
3	GEN193500126	MANUAL STRARTING COMPONENTS	1
4	GEN380140002	BOLT, FLANGE M6×16	4
5	GEN380940346	CABLE CLEAT	1
6	GEN380310168	TAPPING SCREW	1
7	GEN140280001	CLIP, HARNESS	1
8	GEN380930027	LOCATION CABLE CLIP	1

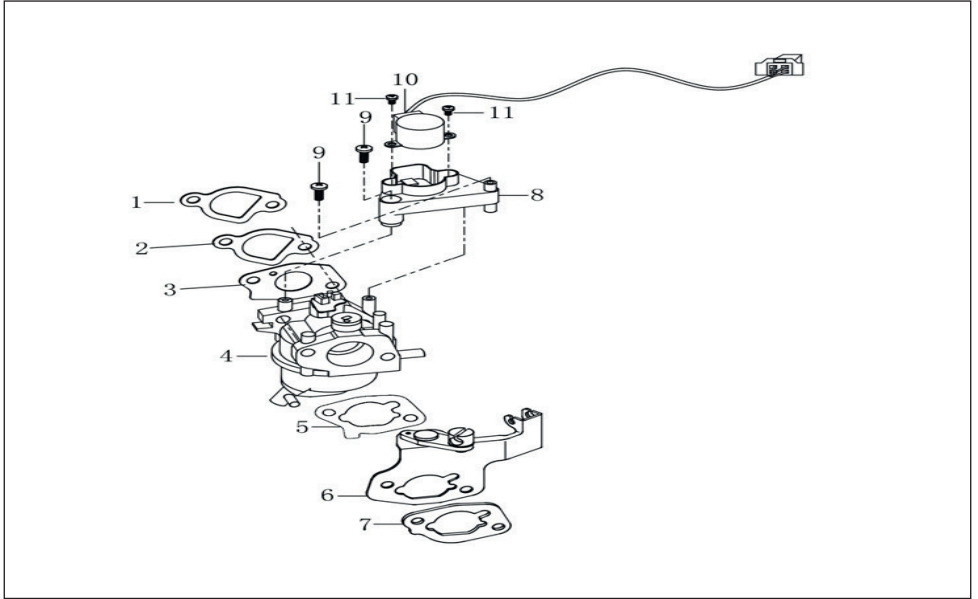

CARBURETOR			
Ser.No	P/N Maxima	Description	Quantity
1	GEN170430060	PACKING, INSULATOR	1
2	GEN170440087	INSULATOR,CARBURETOR	1
3	GEN170430048	PACKING ., CARBURETOR	1
4	GEN170020538	CARBURETOR	1
5	GEN170430140	GASKET, CARBURETOR	1
6	GEN171480028	BRACKET CHOKE	1
7	GEN170430180	SPACER COMP., AIR CLEANER	1
8	GEN660920001	BRACKET, ELETROMOTOR	1
9	GEN380200046	SCREW, TAPPING , M4x12	2
10	GEN660910003	SPEED VARIABLE STEPPER MOTOR	1
11	GEN380200069	SCREW, M3X5	2

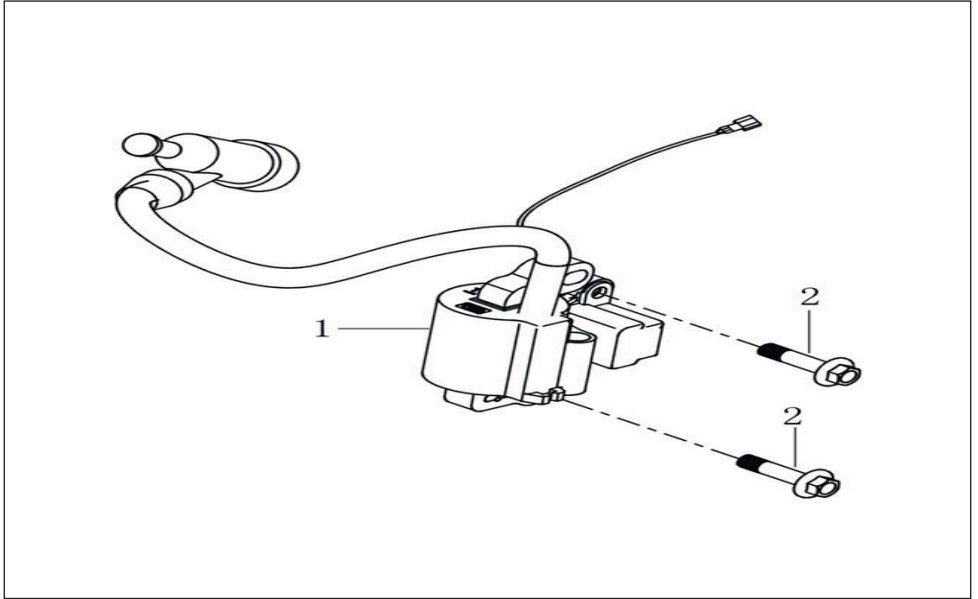

IGNITION COMP.			
Ser.No	P/N Maxima	Description	Quantity
1	GEN270920316	COIL ASSY., IGNITION	1
2	GEN380140102	BOLT, FLANGE M6×25	2

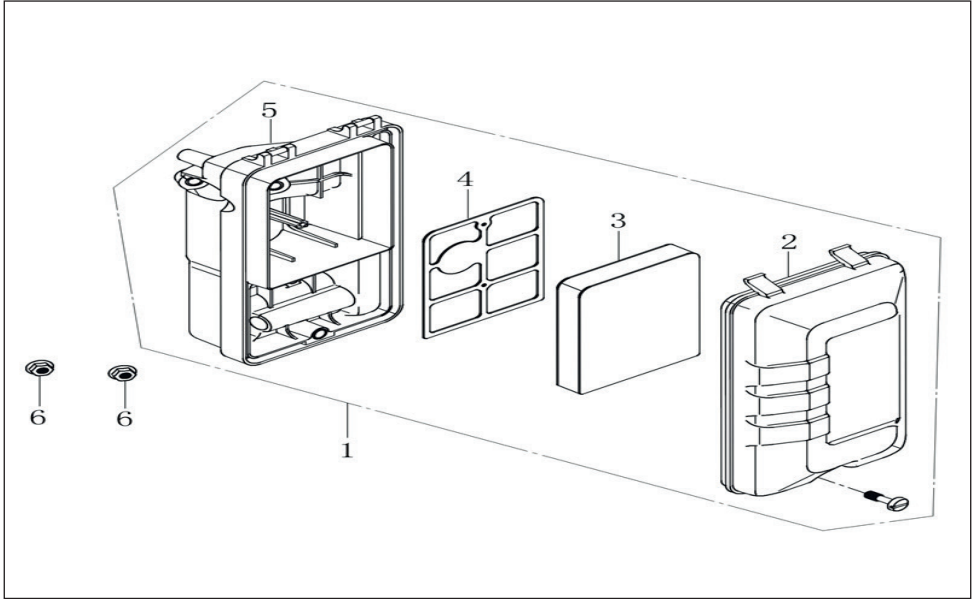

AIR CLEANER			
Ser.No	P/N Maxima	Description	Quantity
1	GEN180020735	AIR CLEANER	1
2	GEN180070220	COVER, AIR CLEANER	1
3	GEN180130257	FILTER, OUTER	1
4	GEN180330050	SEPARATOR, AIR CLEANER	1
5	GEN180280084	COLLAR, AIR CLEANER	1
6	GEN380370048	NUT, FLANGE	2

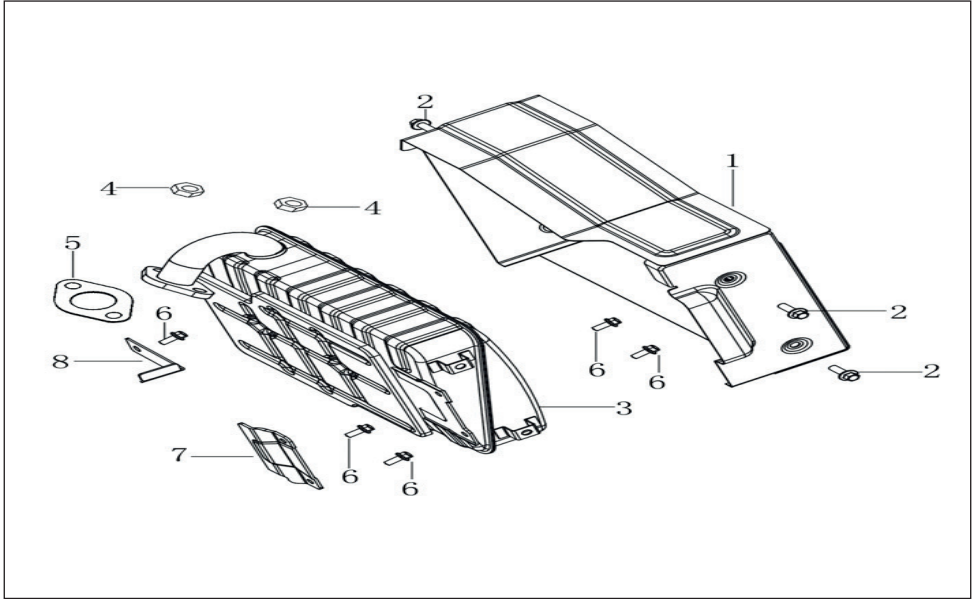

MUFFLER			
Ser.No	P/N Maxima	Description	Quantity
1	GEN180960139	PROTECTOR, MUFFLER	1
2	GEN380140001	BOLT, FLANGE 6X12	4
3	GEN180690176	MUFFLER COMP	1
4	GEN380340005	NUT M8	2
5	GEN180650065	GASKET, MUFFLER	1
6	GEN380140001	BOLT, FLANGE 6X12	5
7	GEN180990090	MUFFLER BRACKET	1
8	GEN341060075	WINDSHIELD	1

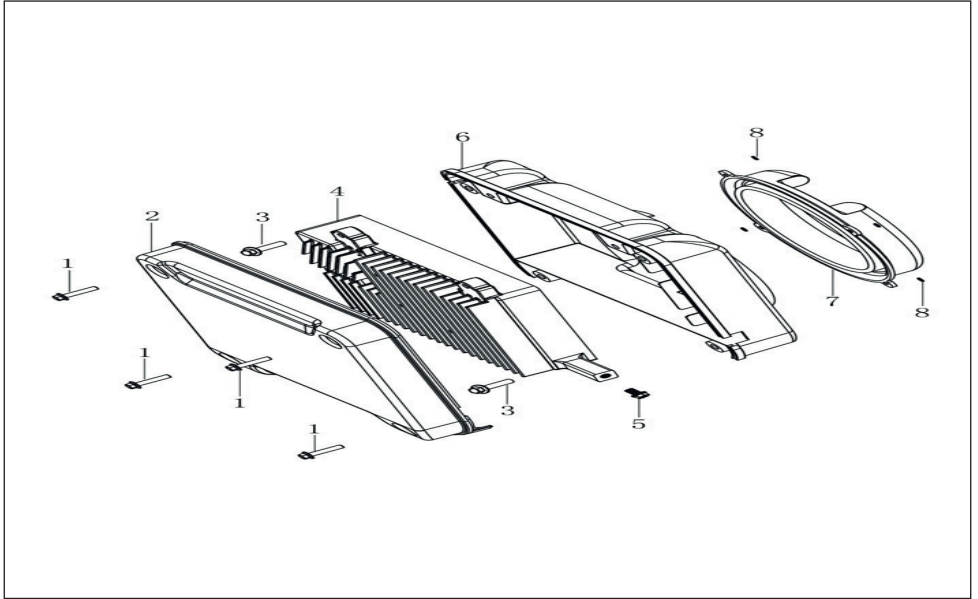

INVERTER ASSY			
Ser.No	P/N Maxima	Description	Quantity
1	GEN380140049	BOLT, FLANG M5×16	4
2	GEN661880004	WIND SHIELD	1
3	GEN380140103	BOLT, FLANGE M6×25	2
4	GEN660900017	INVERTER ASSY.	1
5	GEN380140001	BOLT, FLANGE	1
6	GEN661880005	WIND SHIELD, AFTER	1
7	GEN380840907	SEAL RING	1
8	GEN380490019	LOCK WASHER	4

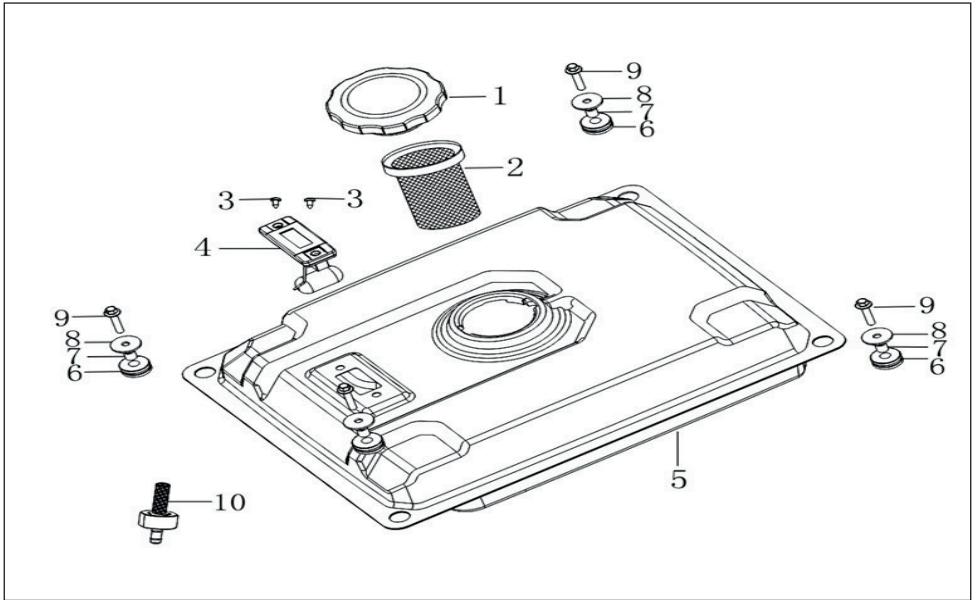

FUEL TANK			
Ser.No	P/N Maxima	Description	Quantity
1	GEN170870129	CAP COMP., FUEL FILLER	1
2	GEN170720005	FILTER, FUEL TANK	1
3	GEN380220009	SCREW, FLAT, 5x16	2
4	GEN170740021	METER COMP., FUEL	1
5	GEN170501067	TANK COMP., FUEL	1
6	GEN170700050	RUBBER, FUEL CUSHION	4
7	GEN170710014	COLLAR, TANK CUSHION	4
8	GEN380450444	WASHER	4
9	GEN380140103	BOLT, FLANGE, M6x25	4
10	GEN170660110	TANK OUTLET	1

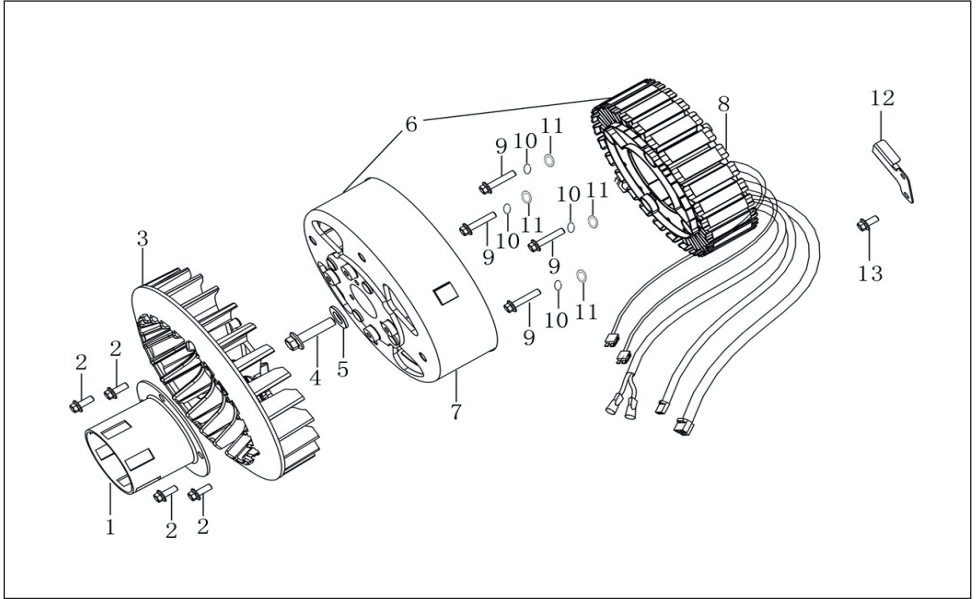

ROTOR.STATOR			
Ser.No	P/N Maxima	Description	Quantity
1	GEN193590026	PULLEY, STARTER	1
2	GEN380140002	BOLT, FLANGE M6×16	4
3	GEN660130007	MOTOR FAN	1
4	GEN380140595	BOLT, FLANGE M8×30	1
5	GEN380451024	WASHER	1
6	GEN660080438	ALTERNATOR ASSY.	1
7	GEN660110105	MOTOR ROTOR	1
8	GEN660100140	MOTOR STATOR	1
9	GEN380190221	INNER SIX ANGLE SCREW	4
10	GEN380460003	WASHER, SPRING	4
11	GEN380450077	WASHER	4
12	GEN110480030	PRESSING LINE PLATE	1
13	GEN380140011	BOLT, FLANGE	1

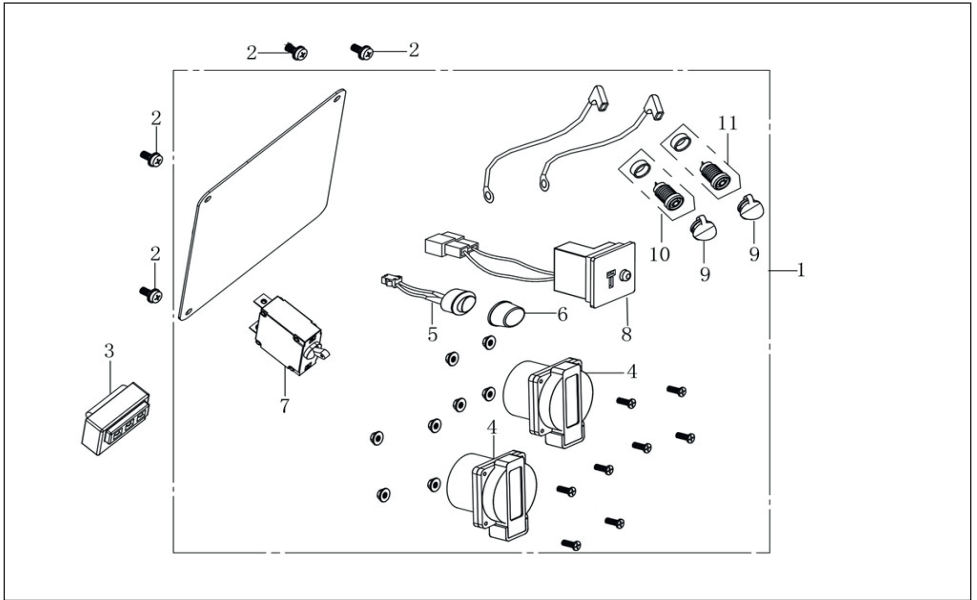

CONTROL PANEL			
Ser.No	P/N Maxima	Description	Quantity
1	GEN271851608	CONTROL PANEL ASSY	1
2	GEN380690017	CROSS-CAP SCREWS	4
3	GEN271000216	ELECTRIC FIREARMS	1
4	GEN271890001	POWER SOCKET COMBINATION	2
5	GEN173400003	IDLE SWITCH	1
6	GEN273330005	IDLING SWITCH WATERPROOF CAP	1
7	GEN350PROCIR	PROTECTOR, CIRCUIT	1
8	GEN381070010	DC SOCKET (WITH THE FLOW DEVICE)	1
9	GEN273330006	GRID SOCKET WATERPROOF GLUE SETS	2
10	GEN381070011	GRID SOCKET (RED)	1
11	GEN381070011	GRID SOCKET (BLACK)	1

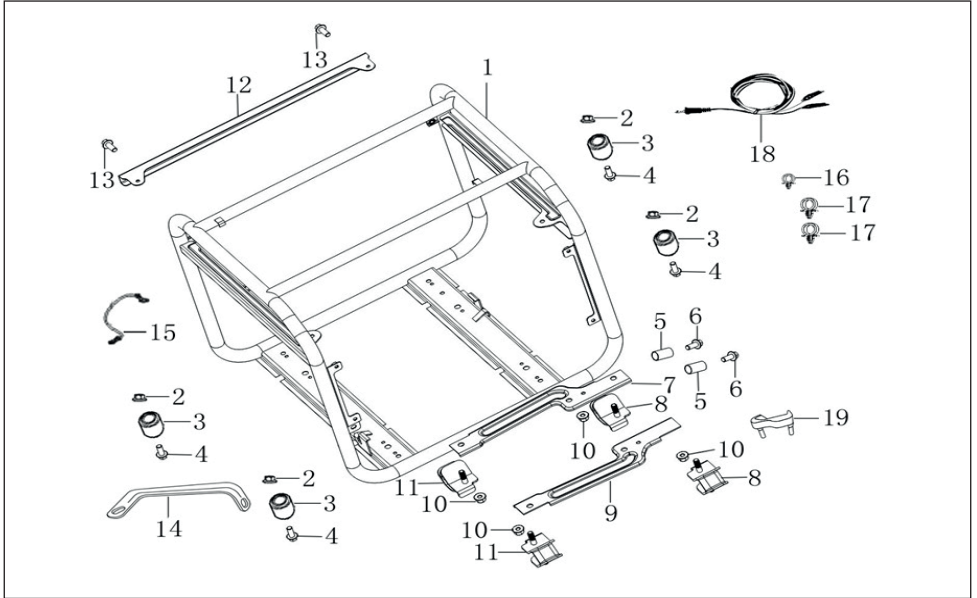

FRAME			
Ser.No	P/N Maxima	Description	Quantity
1	GEN300720364	FRAME COMP	1
2	GEN380370048	NUT M6	4
3	GEN300770005	RUBBER, SHOCK ABSORBER	4
4	GEN380140001	BOLT, FLANGE	4
5	GEN380600117	POSITIONING PIN	2
6	GEN380140091	BOLT, FLANGE,M8x25	2
7	GEN341950005	ENGINE SUPPORT PLATE	1
8	GEN300780022	RUBBER, RIGHT BOTTOM 38	2
9	GEN341950006	ENGINE SUPPORT PLATE	1
10	GEN380370007	NUT M8	4
11	GEN300780023	RUBBER, LEFT BOTTOM 13	2
12	GEN303070038	FRAME PLATE	1
13	GEN380140001	BOLT	2
14	GEN300710112	STAY, AIR CLEANER	1
15	GEN272980006	GROUND LINE	1
16	GEN380930024	LOCATION CABLE CLIP	1
17	GEN380930027	LOCATION CABLE CLIP	2
18	GEN271280039	CONNECTING LINE	1
19	GEN662690001	DRAIN RUBBER	1

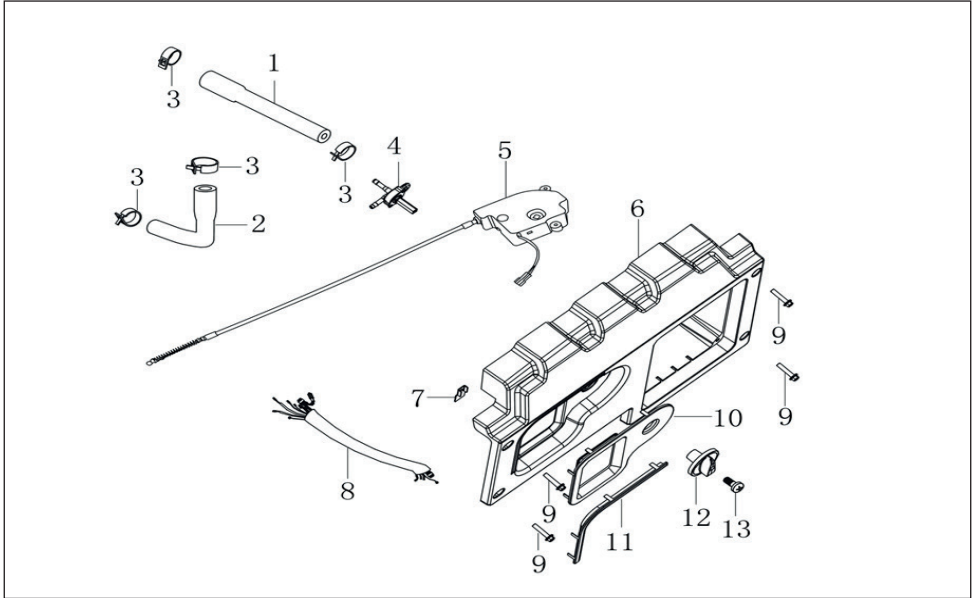

PANEL SEAT			
Ser.No	P/N Maxima	Description	Quantity
1	GEN380750693	TUBE, FUEL	1
2	GEN380750692	TUBE, FUEL	1
3	GEN380960170	CLAMP ASSEMBLY	4
4	GEN170980110	OIL SWITCH PARTS	1
5	GEN661920008	COMBINED SWITCH PARTS	1
6	GEN271970016	PANEL SEAT	1
7	GEN110480031	PRESSING LINE PLATE	1
8	GEN272040131	CONTROL PANEL WIRING HARNESS	1
9	GEN380140049	BOLT, FLANGE	4
10	GEN661940002	PULL ROPE HANDLE EXPORT DECORATIVE	1
11	GEN662370001	WEARE PROTECTIVE STRIP	1
12	GEN173260006	OIL SWITCH KNOB	1
13	GEN381210034	CROSS RECESSED SMALL PAN HEAD TAPPING	1



EC DECLARATION OF CONFORMITY



For the following machinery:

Product name: GENEMAX 3500 IO
 Commercial name: GENEMAX 3500 IO
 Function: Low-power generating set
 Type: Gasoline
 Model number: GENEMAX3500IO Serial
 number: --

is herewith confirmed to fulfill all the relevant provisions of

- Machinery Directive (2006/42/EC)

and the following harmonized standard have been complied with:

- EN ISO 8528-13:2016

is herewith confirmed to fulfill all the relevant provisions of

- Electromagnetic Compatibility Directive (2014/30/EU)

and the following harmonized standard have been complied with:

- EN 61000-6-1:2007; EN 55012:2007+A1

is herewith confirmed to fulfill all the relevant provisions of

- Noise Emission Directive by equipment for use outdoors (2000/14/EC + 2005/88/EC)

MODEL	Measured sound power level dB(A)	Guaranteed sound power level dB(A)
GENEMAX3000IS, GENEMAX3500IS	87	88
GENEMAX7000IS	90	92
GENEMAX3500IO	95	96

Responsible for marking this declaration is the

Manufacturer's Name : MAXIMA S.p.A.
 Manufacturer's Address : Via G. Matteotti, 6 - 42028 Poviglio RE - Italy

Person responsible for compiling the technical files established within the EU

Name, Surname : MAXIMA S.p.A.
 Address : Via G. Matteotti, 6 - 42028 Poviglio RE - Italy

Person responsible for making this declaration

Name, Surname : Mirco Dall'Olio
 Position/Title : Presidente e AD
 Place : Poviglio
 Date : 2022-05-18

(signature)

